

Ventura

interactive kiosk



The Ventura is an evolution of one of our most versatile and popular kiosks. It combines all the qualities, functionality and application capabilities of our kiosk portfolio with advanced commerce and transaction capabilities.

Solid and robust: The highly-engineered chassis ensures durability and reliability within intensive, low supervision environments.

Small footprint: Crucial for any location where space is at a premium.

Secure: Delivers high levels of security for commerce functionality, ever more important as transacting and bill payments on-line become more commonplace and security of cash or credit card services is paramount.

PC based: Supports a range of PCs.

Rich portfolio of options: A broad range of commerce, transaction and payment options.



*Options, at extra cost **Only available in selected locations.

Ventura

Technical Specifications



| | | |
|------------------------------------|---|--|
| Operating Environment | Temperature | 6-32°C (primarily limited by the terminal processor) |
| | Humidity | 20-80% Non-Condensing |
| | Ventilation | Natural Convection Cooling |
| Mains Input | Standard | 220-240VAC ±10% 50Hz |
| | Power | 300W average (500W max.) excluding internal power outlet |
| | Internal Auxiliary DC Supply Rails | 5V, 12V & 24V |
| LCD Monitor | Screen Size | 15" Angle: 45° (from horizontal) |
| | Viewing Angle | 70°/70°/55°/65° (L/R/T/B) |
| | Contrast Ratio | 300:1 |
| | Max. Resolution | 1024x768 @ 16 million colours |
| Touch screen | High quality SAW 15" Antiglare Touch screen | |
| | Interface: RS232 (DCE) 9600bps | |
| | Resolution: 4096 x 4096 | |
| Kiosk Dimensions | Height | 1220mm |
| | Width | 470mm |
| | Depth | 450mm |
| | Weight | 80kg (90kg with transport packaging) |
| Max PC Dimensions | Height | 318mm |
| | Width | 380mm |
| | Depth | 97mm |
| Guardian Kiosk Management Module** | Printer Monitoring: Paper Low / Out / Jam | |
| | CPU / Application Heartbeat Monitoring | |
| | Door Sensor / Auxiliary Device Monitoring | |
| Options* | 110 V Switchable PSU / Stereo Audio System / A4/Receipt Thermal Printer / Guardian Kiosk Management Module / FPOS capabilities / Ruggedised Phone Handset / Ruggedised Keyboard / Signage | |
| Applications | Information, Reception, Promotions, Form completion, HR Applications, Demonstration, Gaming, Transactional, Commerce | |

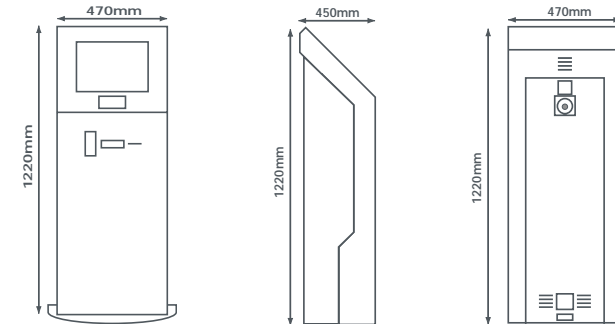

United Kingdom

NeoProducts (UK) Limited
 69 Melchett Road,
 Kings Norton Business Centre,
 Birmingham, B30 3HP, UK
 Tel. +44 (0)121 486 4300
 Fax. +44 (0)121 486 4334
 Email. neo@neoproducts.co.uk

Australia

NeoProducts Pty Ltd
 47 Overseas Drive, Noble Park,
 Victoria, 3174, Australia
 Tel. +61 (0)3 9701 1511
 Fax. +61 (0)3 9701 1799
 Email. neo@neoproducts.com.au

www.neoproductsgroup.com

interactive communication

* Options available on Kiosk, at extra cost

** The application and/or browser running on the Kiosk must support the Guardian. For further details contact NeoProducts.